

ISORIA 10



The ISORIA 10 series, developed by AMRI-KSB, is the answer to many block and control applications that may be encountered in all sectors of industry.

Designed for an allowable pressure of 150 psig (10 bar), the ISORIA 10 valves range in size from 1 ½ to 60 inch.

This technical leaflet supplies technical information concerning these valves.

AMRI is ISO 9001 approved



Contents

	Page
Manufacturing program - Design - Dimensional characteristics	3
Hydraulic characteristics	4
Operating torques	4 & 5
Materials	5, 6 & 7
Pressure and Vacuum limits	7
Flange connections	8
Tests – Inspection	8
Marking – Coating	8
Construction - Parts list	9 & 10
Dimensions and weight - Type 1	11
Dimensions and weight - Type 2	12
Dimensions and weight - Type 4	13 & 14
Dimensions and weight - Type 5	15 & 16
Dimensions and weight - Type 6	17 & 18
Flanging dimensions	18
Installation	19
Data to be supplied upon request or when ordering	20

Manufacturing range

Designed for an allowable pressure of 150 psig (10 bar), the ISORIA 10 valves are available in five body types:

- wafer type,
- semi-lug type,
- full lug type with raised faces,
- flanged type body with flat faces,
- U-section body with raised faces.

Body shape	Type	Size (in)
Wafer type body with flat faces allowing dead-end service under max ...p	1	1 ½ to 24
Semi-lug type body with flat faces, allowing downstream dismantling and/or dead-end service under max ...p	2	1 ½ to 24
Full-lug type body with raised faces, allowing downstream dismantling and/or dead-end service under max ...p	4	1 ½ to 24
Flanged type body with flat faces, allowing downstream dismantling and/or dead-end service under max ...p	5	6 to 60*
U-section body with raised faces, allowing downstream dismantling and/or dead-end service under max ...p	6	26 to 60*

* Size 1500 mm – 60": ...p 90 psi

Size 125 mm – 5"

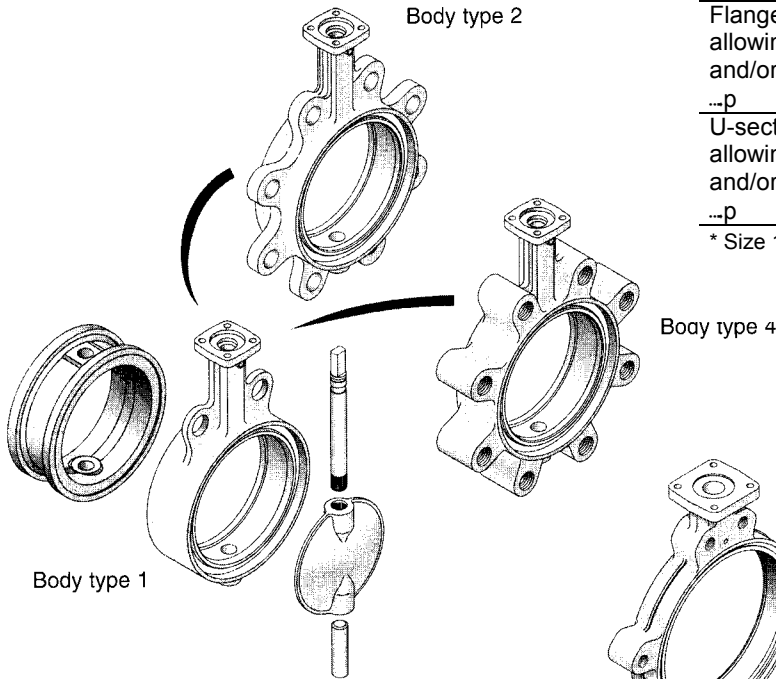

Size 350 mm – 14"

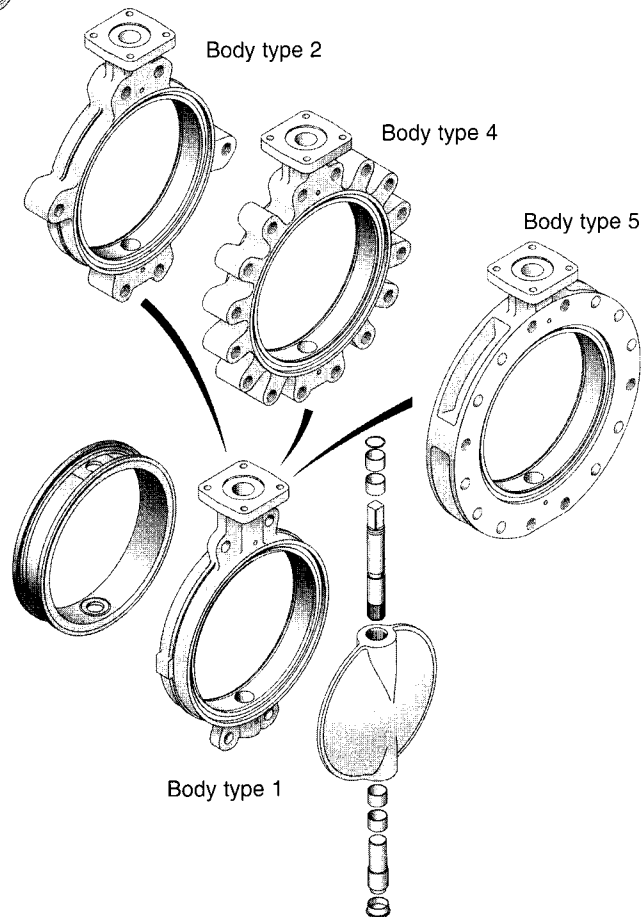

Design

The ISORIA 10 butterfly valves are designed in accordance with EN 593 standard (NF E 29-430 and 29-431).

Dimensional characteristics

The ISORIA 10 valves conform to the following standards:

- Face-to-face dimensions:

- ISO 5752 series 20,
- EN 558.1 series 20,
- API 609.

- Actuation mounting plate:

- ISO 5211.

Hydraulic characteristics

Flow coefficients

The following table gives the flow coefficients relating to the opening angle of the disc.

The flow coefficient Cv is the flow in US gallons per minute passing through a valve with a resulting pressure drop of 1 psig.

Flow coefficients Cv in gallon US/mn/psi^{1/2}

Size		Flow coefficient Cv relating to the opening angle of the disc								
mm	Inch	10°	20°	30°	40°	50°	60°	70°	80°	90°
40	1 ½	0	1	3	6	11	18	31	55	61.5
50	2	0	2	7	15	28	46	77	139	154
65	2 ½	0	4	13	28	50	84	140	252	280
80	3	0	7	21	48	86	143	238	428	475
100	4	1	11	34	76	137	228	380	684	760
125	5	1	16	47	104	188	313	522	940	1044
150	6	2	31	94	209	376	627	1045	1881	2090
200	8	4	62	185	412	742	1236	2060	3708	4120
250	10	8	127	380	845	1521	2536	4226	7607	8453
300	12	10	157	471	1047	1884	3140	5233	9419	10465
350	14	13	193	580	1288	2318	3864	6440	11592	12880
400	16	17	255	766	1702	3064	5106	8510	15318	17020
450	18	23	340	1019	2266	4078	6797	11328	20390	22655
500	20	29	431	1294	2875	5175	8625	14375	25875	28750
550	22	36	547	1640	3646	6562	10937	18228	32810	36455
600	24	42	628	1884	4186	7535	12558	20930	37674	41860
650	26	36	542	1625	3610	6498	10830	18050	32490	36100
700	28	40	594	1782	3960	7128	11880	19800	35640	39600
750	30	48	720	2160	4800	8640	14400	24000	43200	48000
800	32	55	819	2457	5460	9828	16380	27300	49140	54600
900	36	69	1037	3110	6910	12438	20730	34550	62190	69100
1000	40	96	1437	4311	9580	17244	28740	47900	86220	95800
1050	42	118	1775	5324	11830	21924	35490	59150	106470	118300
1100	44	130	1950	5850	13000	23400	39000	65000	117000	130000
1200	48	130	1950	5850	13000	23400	39000	65000	117000	130000
1350	54	209	3132	9396	20880	37584	62640	104400	187920	208800
1400	56	224	3357	10071	22380	40284	67140	111900	201420	223800
1500	60	270	4055	12164	27030	48654	81090	135190	243270	270300

Operating torques for liquid and gas applications

The operating torques (in. lbs.) stated in the tables below are the maximum torques encountered near the closed position when the disc edge compresses the liner.

These torques include:

- the manufacturing tolerances,
- the different natures of elastomers,
- the variations of the elastomer characteristics due to the temperature.

No additional safety factors are necessary. In the intermediate position and up to the fully open position, the running torque is approximately 1/10 of the maximum values.

Note: an increase of the running torque in the intermediate position can be generated by the liquid flow hydrodynamics when the flow velocity exceeds 10 ft/sec.

Size		Maximum torque in in.-lbs.	
mm	inch	XA, XV, K liners on lubricated medium	XA, XV, K liners on non lubricated medium Other liners (1)
40	1 ½	89	177
50	2	177	265
65	2 ½	265	354
80	3	354	443
100	4	531	620
125	5	708	885
150	6	1150	1239
200	8	1504	1858
250	10	1947	2921
300	12	3363	4602
350	14	4425	6372
400	16	5752	8673
450	18	7080	10620
500	20	8850	13275
550	22	10620	15930
600	24	12390	18585

Size		Maximum torque in in.-lbs.	
mm	inch	XA, XV, K liners on lubricated medium	XA, XV, K liners on non lubricated medium Other liners (1)
650	26	15930	23895
700	28	18585	28320
750	30	21240	31860
800	32	24780	36285
900	36	31860	46020
1000	40	38940	56640
1050	42	44250	66375
1100	44	44250	66375
1200	48	57531	84075
1350	54	97350	141600
1400	56	97350	141600
1500	60	71685 (2)	110625 (2)

(1) on lubricated or non lubricated media

(2) allowable pressure p_s 6 bar

(Refer to Page 5 for undercut disc torques)

UNDERCUT DISC TORQUES

Size		Maximum torque in in.-lbs.		Size		Maximum torque in in.-lbs.	
Mm	Inch	XA, XV, K liners on lubricated medium	XA, XV, K liners on non lubricated medium	Mm	Inch	XA, XV, K liners on lubricated medium	XA, XV, K liners on non lubricated medium
40	1 ½	45	89	250	10	974	1460
50	2	89	133	300	12	1682	2301
65	2 ½	133	177	350	14	2212	3186
80	3	177	222	400	16	2876	4337
100	4	265	310	450	18	3540	5310
125	5	354	443	500	20	4425	6638
150	6	575	620	550	22	5310	7965
200	8	752	930	600	24	6195	9293

Max ΔP = 50 psi

Materials

The materials used for the construction of ISORIA 10 valves and their mechanical characteristics are listed in the following tables. They conform to the standards in gray blocks, and are equivalent to the standards in the white blocks. On request, certificates of material conformity can be supplied.

Body: one piece cast with an extended neck for pipe insulation.

AMRI KSB code	Material Type	Designation in accordance with standards			Mechanical characteristics		
		EN	ASTM	JIS	Uts ksi	Yp ksi	% El.
1	Carbon steel	GP240GH (1)	A 216 gr. WCC	JIS G5101 SC 49	≥ 70	≥ 39	≥ 22
3g	Ductile iron	JS 1030 (2)	A 536 gr.60-40-18	JIS G5502 FCD 40	≥ 58	≥ 36	≥ 15
3t	Cast iron	JL 1040 (3)	A 48 cl.35	JIS G5501 FC 25	≥ 36	----	----

Uts: Ultimate tensile strength - Yp: Yield point - El: Elongation

(1) Previous standards: DIN 17245 GSC-25

(2) Previous standards: DIN GGG 40 / NF FGS 400-15

(3) Previous standards: DIN GG 25 / NF FGL 250

The table below defines the body material relating to its shape.

Model	Type	Material	Size (inch)
Wafer type	1	Cast iron - code 3t	1 ½ to 24
Semi-lug type	2	Ductile iron - code 3g	1 ½ to 24
Full-lug type with raised faces	4	Cast iron - code 3t	1 ½ to 24
		Ductile iron - code 3g	1 ½ to 24
Flanged type body with flat faces	5	Ductile iron - code 3g	6 to 60
U-section body With raised faces	6	Cast iron - code 3t	26 to 40
		Ductile iron - code 3g	26 to 60
		Carbon steel - code 1	26 to 60

Shafts: in two parts, with anti blowout device. Double D Shaft for sizes 1 ½" to 12" and square shaft for sizes 14" to 60". The shaft/disc connection is achieved by splines for 24" and smaller, and by internal keys for 26" and larger.

AMRI-KSB code	Material type	Designation in accordance with standards			Mechanical characteristics			
		EN	ASTM	JIS	Uts ksi	Yp ksi	% El.	
6k *	13% Cr stainless steel	EN 10088-3 A 35-574	X29 CrS13	-----		123 to 145	≥ 94	≥ 9
6e *	17-4 type stainless steel		X5CrNiCuNb16-4 N° 1.4542 or X4CrNiMo16-5-1 N° 1.4418	A 564 gr. 630	JIS G4303 SUS 630	≥ 130	≥ 101	≥ 9
8	Nickel alloy MONEL K500 aged		-----			≥ 132	≥ 93	≥ 15

Uts: Ultimate tensile strength - Yp: Yield point - El: Elongation

* 6k: standard version shafts for all sizes, except sizes 48" to 56" shafts 6e.

The opposite table defines the various shaft materials relating to the valve size.

Size		Material
mm	inch	
40 to 600	1 ½ to 24	6k * - 6e - 8
650 to 1100	26 to 44	6k * - 6e - 8
1200 to 1400	48 to 56	6e * - 8
1500	60	6k * - 6e - 8

* Standard version

Disc: spherically machined, cast or forged depending on the size and the materials.

AMRI KSB code	Material type	Designation in accordance with standards						Mechanical characteristics			Size inch
		EN	ASTM	BS	DIN	UNI	JIS	U _{ts} MPa	Y _p MPa	El. A %	
3g	Ductile iron	JS 1030 (1)	A 536 gr.60-40-18	-----	-----	-----	JIS G5502 FCD 40	≥ 400	≥ 250	≥ 15	1 1/2" to 60"
6	18-12 type stainless steel	NF A 32-060 Z6CND18-12M	A 351 gr. CF8M	BS 1504 316C16	DIN 17245 GX6CrNi Mo 18-10 N° 1.4408	UNI 6901 X5CrNiMo 17-12	JIS G5121 SCS 14	≥ 530	≥ 240	≥ 35	10" to 60"
		NF EN 10088-3 A35-574 X5CrNiMo17-12-2 1.4401	A 182 gr. F316	-----				≥ 515	≥ 205	≥ 30	1 1/2 " to 8"
2	Aluminum-bronze	NF A 53-709 CuAl10Fe5Ni5	B148-955	BS 1400 A B2	DIN 1714 GCuAl10Ni	UNI 5275 CuAl11Fe4 Ni4	JIS 5114 AIBC3	≥ 630	≥ 250	≥ 12	1 1/2" to 60"
6i	18-12 type stainless steel polished	Same grade and characteristics as 18-12 type stainless steel (code 6)									1 1/2' to 40"
3a (2)	HALAR [®] coated ductile iron	Same grade and characteristics as ductile iron (code 3g)									1 1/2' to 60"
3b (2)	Titanium carbide coated ductile iron	Same grade and characteristics as ductile iron (code 3g)									1 1/2' to 60"
3p (2)	Hard rubber coated ductile iron	Same grade and characteristics as ductile iron (code 3g)									4" to 60"
5c (2)	NORICLOR [®]	-----			GX3CrNiMo CuN 24-6-5	-----		≥ 700	≥ 450	≥ 25	1 1/2' to 60"
5d (2)	NORIDUR [®]	-----						≥ 700	≥ 450	≥ 25	1 1/2' to 60"
6u (2)	Austenitic stainless steel type URANUS B6	EN 10 088 X1NiCrMoCu25-20-5 Z2NCDU25-20	A351 CN-7M	BS 1504 332 C11	SEW 410 GX7NiCrMo CuNb25-20	-----		≥ 450	≥ 170	≥ 30	1 1/2' to 60"

U_{ts}: Ultimate tensile strength - Y_p: Yield point - El: Elongation

(1) Previous standards: DIN GGG40 / NF FGS 400-15

(2) For the availability of these materials, please consult us.

NORIDUR[®] and NORICLOR[®] are KSB registered trademarks.

AMRING[®] liner: in-house designed, formulated and manufactured, it ensures perfect leak-tightness at the shaft passages, and the flanges upstream/downstream. The disc and liner are the only parts in contact with the fluid.

AMRING code	Elastomer group	Main properties	Some examples of applications
----------------	--------------------	-----------------	-------------------------------

Standard liners

XA 212°FMax	E.P.D.M.	Good mechanical characteristics. Exceptional resistance to oxidation, ketones, alcohols, mineral and organic acids, acid, neutral or alkaline salts, esters, vegetable or animal oils.	Seawater, sewage,... Ventilation circuits, ozone and ozone derivatives. Weak acids circuits, aldehydes, amines, ketones, esters Food industry: water, wine, beer, milk, alcohols, fruit juice,... Conforms to F.D.A. regulations.
XV 266°FMax	Heat E.P.D.M.	Special formulation for high temperature	Industrial higher temperature processes. Sugar industry (mascuite and juice). Chemical industry. Evaporators.
K 212°FMax	High content nitrile	Good mechanical characteristics. Good resistance to hydrocarbons.	Hydrocarbons and oils with low aromatic content. General services: compressed air, water, fuel.

Liners on request

CB 212°FMax	Carboxylated nitrile	Very good mechanical characteristics. Exceptional resistance to tearing, essential for abrasive services. Good resistance to oils.	Abrasive circuits. High-speed pneumatic transport of pulverized solids.
CC 158°FMax	White carboxylated nitrile	Very good mechanical characteristics.	Pneumatic transport of granules.
Y 212°FMax	HYPALON® chlorosulphonated polyethylene	Good mechanical characteristics. Good resistance to mineral acids, bases, alcohols, animal and vegetable oils. Resistance to ozone.	Soda, potash, phosphoric and superphosphoric acids. Manufacture and treatment of brine in chlorine production. Treatment of steel plates and steel products.
VA 302°FMax	Fluorinated elastomer VITON® acid	Higher resistance to chemical products (at higher temperature) than other elastomers except to ketones, esters and certain alcohols. Special formulation for resistance to aqueous media.	Hot or concentrated mineral acids: chlorhydric and sulfuric acids, acid treatment of ores.
VC 392°FMax	Fluorinated elastomer VITON® high temp	Good resistance to hot gas and solvents (no aqueous media).	Solvents. Oxygen, hot and corrosive gases. Hydrocarbons and refined products ("white products").

Maximum liner temperatures shown for information only, and may be lower depending on the application. Please consult the next table for the working pressure limits.

Working pressure limits and diameter for the AMRING® liners on ISORIA 10 Valve

The table below defines the working pressure limits of the liners relating to the elastomer nature and the diameter.

Size		Standard liners XA XV K	Maximum working pressure (psig)			
mm	inch		Y	VA VC	CB	CC
40 to 150	1 ½ to 6	150	150	150	150	90
200 to 300	8 to 12					
350 to 500	14 to 20					
550	22					
600	24	150	150	150	150	90
650 to 1000	26 to 40					
1050 to 1200	42 to 48					
1300 to 1400	52 to 56					
1500	60	90				

Vacuum limits

For valves used under extreme conditions of vacuum and temperature, depending on the size of valve and the AMRING® liner material, it may be necessary to bond the liner to the body by vulcanization.

It is impossible to remove the liner after vulcanization, and if the replacement of the liner is required, a body / liner set is proposed.

The table below defines vacuum limits and technical conditions.

Size		Pressure		T max °F	Special Construction Requirements
mm	inch	min (psia)	Max (psig)		
40 to 150	1 ½ to 6	0.0002 (10 ⁻² torr)	150	T max of XA and XV liners T 176 °F For other liners	None
200 to 1500	8 to 60	4.35	150 (60 inch: 90 psig)	T max of XA and XV liners T 176 °F For other liners	None
		0.0002 (10 ⁻² torr)	150 (60 inch: 90 psig)	176 °F	Bonded Liner

Connections

The shape of the body has been designed to allow installation into many currently used flange connection standards, mainly:

- PN 6, 10 and 16,
- ANSI B16-1 class 125 and B 16-5 class 150,
- MSS SP 44 class 150,
- AWWA C 207 class B, D and E,
- AS 2129 tables D and E,
- BS 10 tables D and E,
- JIS B 2210 - 5K, 10K and 16K.

Tests - Inspection

Guaranteed performances

Isolating tight shut-off

The ISORIA 10 valves are perfectly tight shut-off (no visible leakage to the naked eye) in either flow direction, in accordance with the following standards:

- ISO 5208 category A,
- NF E 29-311 rate 3,
- DIN 3230 part 3 rate 1,
- API 598,

and all other standards which allow a leakage rate (ANSI/FCI 70-2 class 6 for instance).

Atmospheric tight shut-off

In accordance with the above-mentioned standards, the ISORIA 10 valves are guaranteed 100% leak-tight to atmosphere.

Endurance tests

The endurance of ISORIA 10 valves conforms to EN 593 (March 1998) standard.

Standard tests

Body strength test

1.5 times the allowable pressure with water. This test is performed after valve assembly and with the disc in half open position

Upstream/downstream and shaft tight shut-off test

1.1 times the allowable pressure with water.

Operating test

During final inspection, each valve and its actuator, undergoes a complete operating test (open/close). This test is carried out without pressure and at ambient temperature. It ensures the correct operation of the valve/actuator assembly, including the accessories.

Optional tests

On request, any other test can be carried out according to special instructions.

Marking

ISORIA 10 valves marking is in accordance with EN 19 standard.

Marking on cast body

- Name of manufacturer: AMRI
- Nominal size: ND (in millimeters)
- Grade of body material: standardized designation
- Reference number of casting pattern

Marking on the identity plate attached to the body

In addition to the valve name, the identification plate attached to the body includes the month and the year of manufacture, the materials code, body type, allowable pressure in bar, the drilling pattern (if necessary with the thread pitch) and the reference of particular construction (construction S, R 107,.....).

Coating

The body of ISORIA 10 valves are coated with polyurethane paint, thickness 3 mils, color blue ref. RAL 5002.

The discs made of ductile iron (AMRI code 3g) are coated with epoxy powder paint, thickness 2.7 mils, color gray white ref. RAL 7035.

On request, a special coating for food products can be applied to the disc. Please, consult us.

Construction - Sizes 40 to 600 mm (1 1/2" to 24")

Below are cross sectional drawings of ISORIA 10 valve type 1. Except for the external shape of the body, the construction is the same for all types.

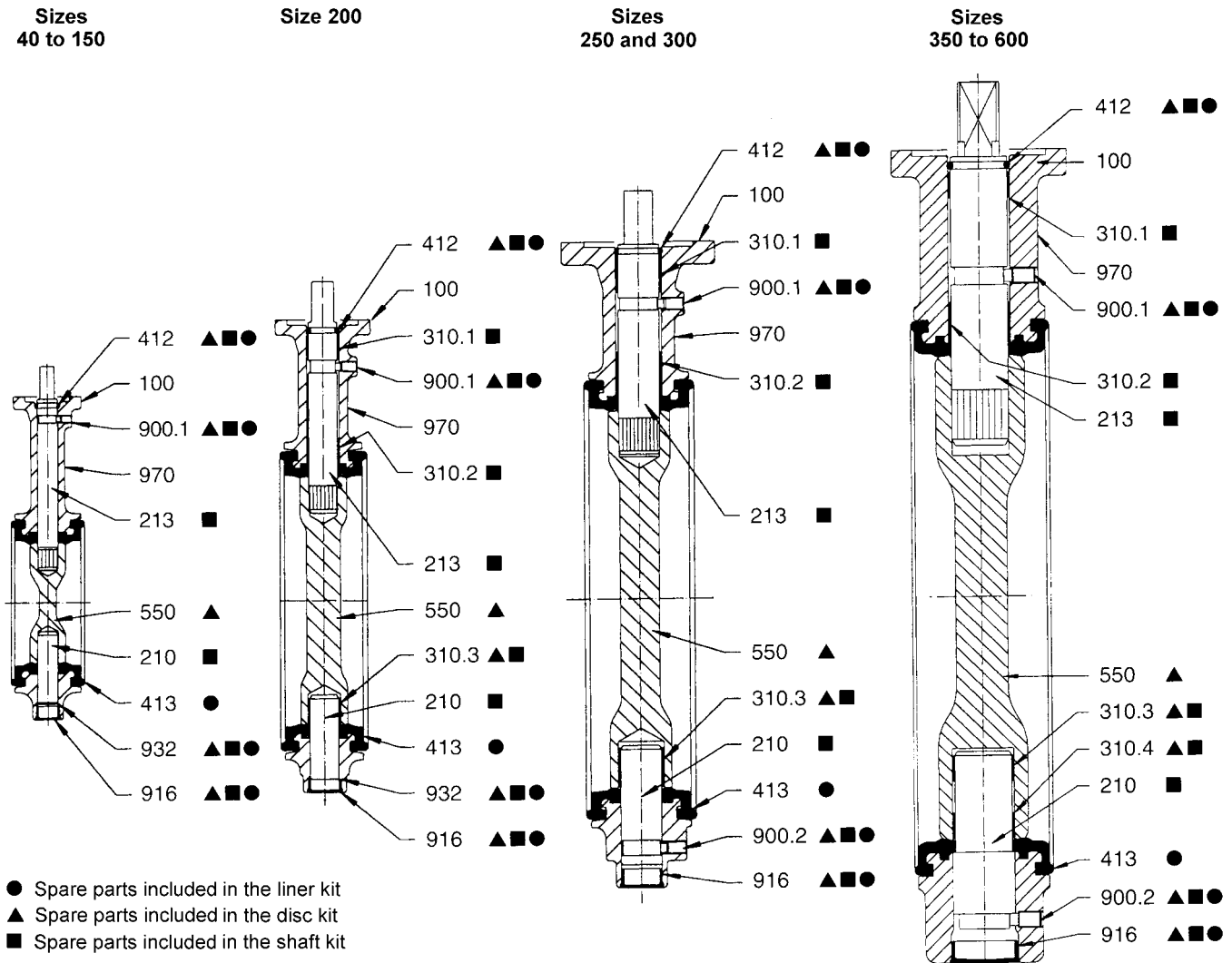

Item	Designation	Size (mm)	Materials
100	Body	40 to 600	Types 1 and 4: JL 1040* cast iron (code 3t) Types 2 and 5: JS 1030** ductile iron (code 3g)
210	Shaft	40 to 600	13% chromium stainless steel (code 6k) in standard version
213	Operating shaft	40 to 600	13% chromium stainless steel (code 6k) in standard version
310.1	Plain bearing	200 to 600	PTFE filled on steel casing
310.2	Plain bearing	200 to 600	PTFE filled on steel casing
310.3	Plain bearing	200 to 600	PTFE filled on steel casing
310.4	Plain bearing	350 to 600	PTFE filled on steel casing
412	O-Ring	40 to 600	Nitrile
413	Liner	40 to 600	In accordance with fluid
550	Disc	40 to 600	In accordance with fluid
900.1	Anti blow-out screw	40 to 600	Stainless steel
900.2	Anti blow-out screw	250 to 600	Stainless steel
916	Plug	40 to 600	Polyamide
932	Spring retaining ring	40 to 200	Steel
970	Identity plate	40 to 600	Polyester + adhesive

* Previous standards: DIN GG 25 / NF FGL 250

** Previous standards: DIN GGG 40 / NF FGS 400-15

Construction - Sizes 650 to 1500 mm (26" to 60")

Below are the cross sectional drawings of ISORIA 10 valve type 5. Except for the external shape of the body (flat or raised faces), the construction is the same for the body types, 5 and 6.

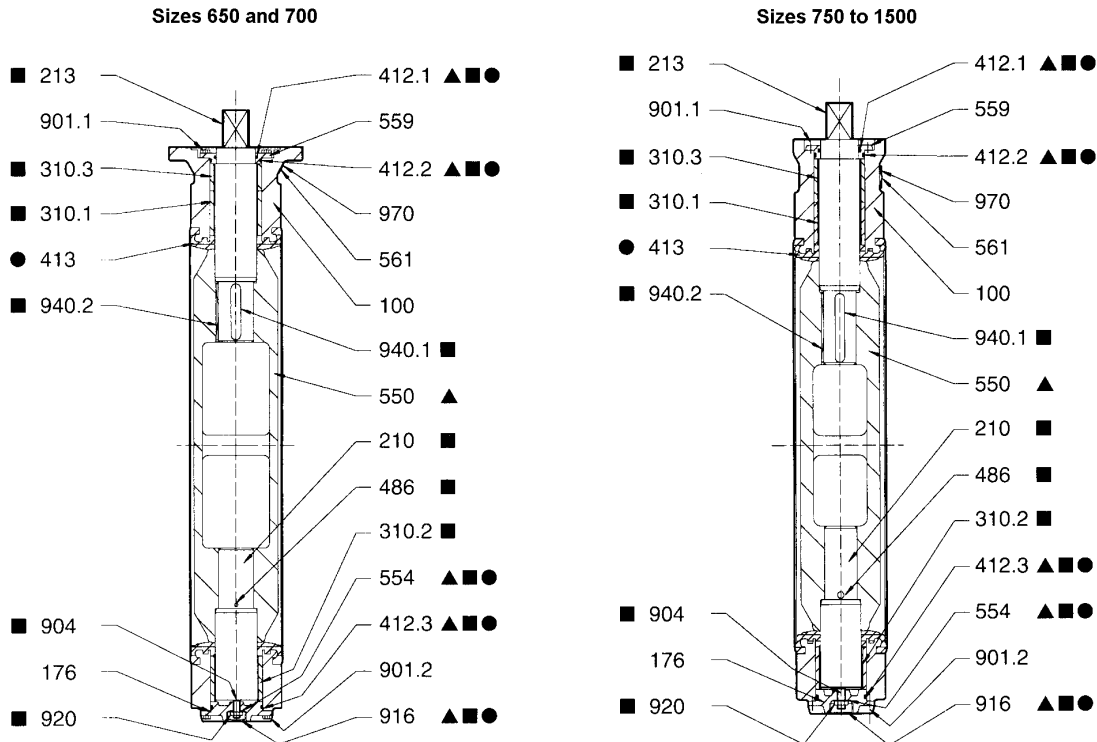

- Spare parts included in the liner kit
- ▲ Spare parts included in the disc kit
- Spare parts included in the shaft kit

Item	Designation	Size (mm)	Materials
100	Body	650 to 1500	Type 5 JS 1030** ductile iron (code 3g)
		650 to 1500	Type 6 JS 1030** ductile iron (code 3g)
		650 to 1000	JL 1040 * cast iron (code 3t)
		650 to 1500	ASTM A 216 gr.WCC carbon steel (code 1)
176	Bottom	650 to 1500	JS 1030** ductile iron
210	Shaft	650 to 1500	13% Cr stainless steel (code 6k) or 17-4 stainless steel (code 6e)***
213	Operating shaft	650 to 1500	13% Cr stainless steel (code 6k) or 17-4 stainless steel (code 6e)***
310.1	Plain bearing	650 to 1500	PTFE filled on steel casing
310.2	Plain bearing	650 to 1500	PTFE filled on steel casing
310.3	Plain bearing	650 to 1500	PTFE filled on steel casing
412.1	O-Ring	650 to 1500	Nitrile
412.2	O-Ring	650 to 1500	Nitrile
412.3	O-Ring	650 to 1500	Nitrile
413	Liner	650 to 1500	In accordance with fluid
486	Ball	650 to 1500	Stainless steel
550	Disc	650 to 1500	In accordance with fluid
554	Washer	650 to 1500	Nylon
559	Gasket holder	650 to 1500	JS 1030** ductile iron (code 3g)
561	Grooved nail	650 to 1500	Stainless steel
900.1	Hexagonal screw	650 to 1500	Steel
900.2	Hexagonal screw	650 to 1500	Steel
904	Adjusting screw	650 to 1500	Steel
916	Plug	650 to 1500	Polyethylene
920	Nut	650 to 1500	Steel
940.1	Key	650 to 1500	Steel
940.2	Key	650 to 1500	Steel
970	Identity plate	650 to 1500	Stainless steel

* Previous standards: DIN GG 25 / NF FGL 250 - ** Previous standards: DIN GGG 40 / NF FGS 400-15

*** Shafts 6k in standard version for all sizes, except sizes 1200 to 1400 shafts 6e

Wafer type body - Type 1 – Sizes 40 to 600 mm (1 ½” to 24”)

Dimensions (mm) and weight (lbs)

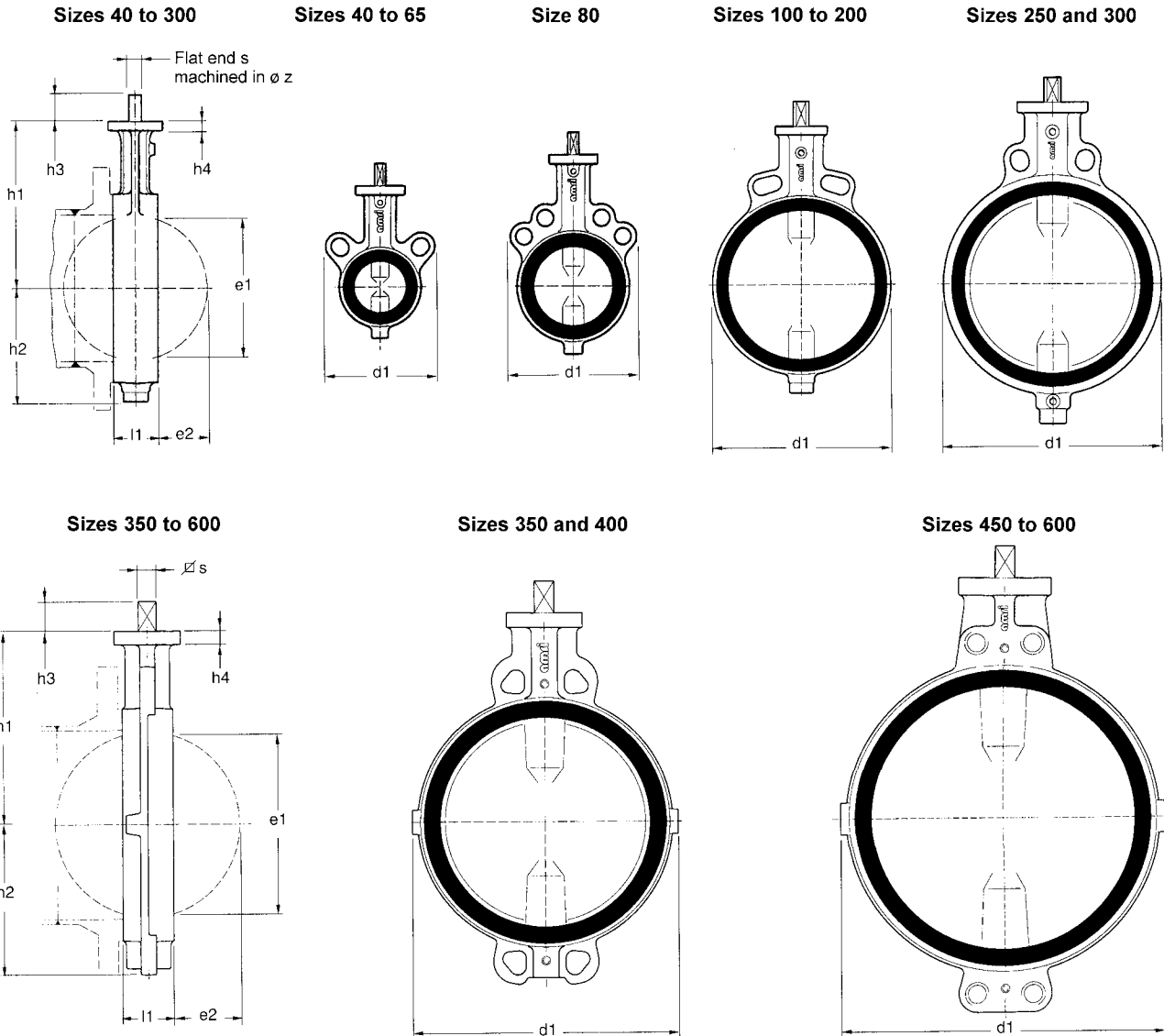

Size		Face to face l1				Mounting plate ISO 5211		Flat shaft end			Square shaft end		Disc clearance		Weight lbs
mm	inch		d1	h1	h2	n°	h4	s	øz	h3	s	h3	e1	e2	
40	1 ½	33	108	105	51	F05	10	11	14	24			32	4	2.4
50	2	43	118	109,5	55,5	F05	10	11	14	24			33	4	2.8
65	2 ½	46	133	136	67,5	F05	10	11	14	24			55	11	4.1
80	3	46	138	142	73,5	F05	10	11	14	24			71	17	5.5
100	4	52	144	163	92	F05	10	14	18	30			90	23	8.5
125	5	56	174	176,5	105,5	F05	10	14	18	30			119	35	10.3
150	6	56	198	194	120	F07	12	14	18	30			144	46	15.2
200	8	60	252	222	150,5	F07	12	19	25	35			196	69	23
250	10	68	310	255	194,5	F10	15	19	25	35			249	92	36
300	12	78	362	282	226	F12	18	22	28	40			297	111	66
350	14	78	433	335	269	F12	23				25	45	326	127	110
400	16	102	490	380	298	F14	23				36	55	370	140	158
450	18	114	546	410	329	F14	23				36	55	422	160	211
500	20	127	600	440	359	F14	27				36	55	470	178	286
550	22	154	645	475	406	F16	27				50	65	522	195	352
600	24	154	714	495	439	F16	27				50	65	566	215	418

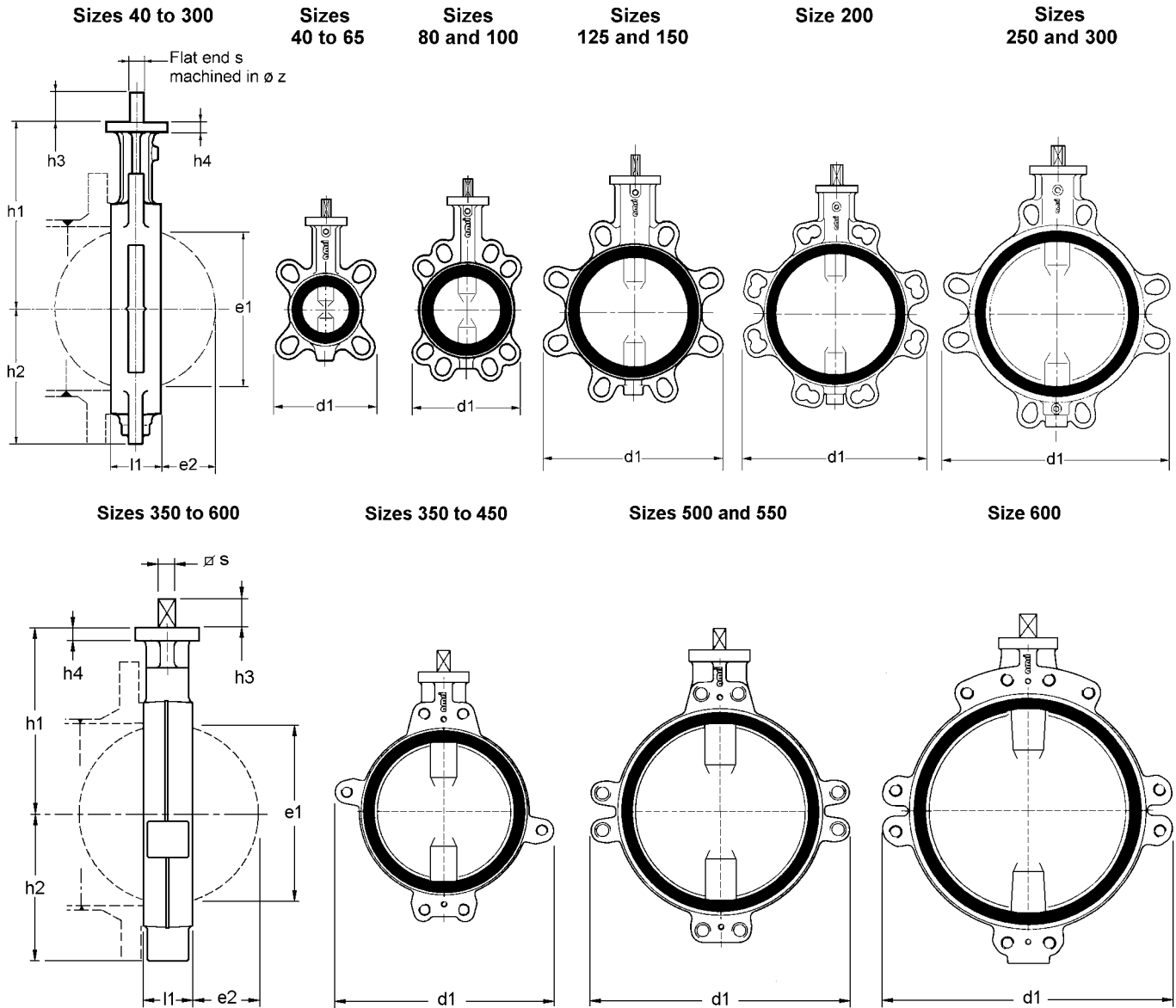
Semi-lug type body - Type 2 – sizes 40 mm to 600 mm (1 ½” to 24”)
Dimensions (mm) and weight (lbs)

Size		Face to face l1			Mounting plate ISO 5211		Flat shaft end			Square shaft end		Disc clearance		Weight lbs	
mm	inch		d1	h1	h2	n°	h4	s	øz	h3	s	h3	e1		e2
40	1 ½	33	108	105	54	F05	10	11	14	24			32	4	2.6
50	2	43	118	109,5	59	F05	10	11	14	24			33	4	3.3
65	2 ½	46	132	136	66	F05	10	11	14	24			55	11	4.8
80	3	46	138	142	89	F05	10	11	14	24			71	17	6.1
100	4	52	150	163	103	F05	10	14	18	30			90	23	9.5
125	5	56	234	176,5	117	F05	10	14	18	30			119	35	12.3
150	6	56	260	194	130	F07	12	14	18	30			144	46	17
200	8	60	322	222	161	F07	12	19	25	35			196	69	26
250	10	68	394	255	197	F10	15	19	25	35			249	92	39
300	12	78	462	282	231	F12	18	22	28	40			297	111	70
350	14	78	538	335	269	F12	23				25	45	326	127	132
400	16	102	604	380	302	F14	23				36	55	370	140	176
450	18	114	656	410	328	F14	23				36	55	422	160	242
500	20	127	716	440	358	F14	27				36	55	470	178	319
550	22	154	804	475	406	F16	27				50	65	522	195	396
600	24	154	836	495	439	F16	27				50	65	566	215	484

Full-lug type body with raised faces - Type 4 – Sizes 40 mm to 600 mm (1 1/2" to 24")
Dimensions (mm) and weight (lbs)

Sizes 40 to 300

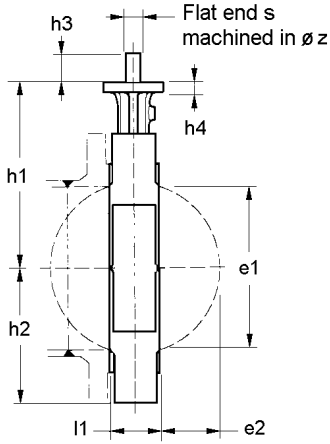

**Sizes 40 to 65
Size 80⁽¹⁾**

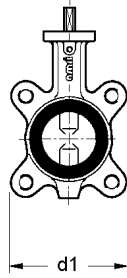

**Size 80⁽²⁾ - Size 100
Size 125 - Size 150
Size 200⁽³⁾**

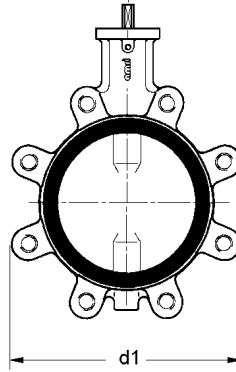

**Size 200⁽⁴⁾ - Size 250
Size 300 - Size 350⁽¹⁾**

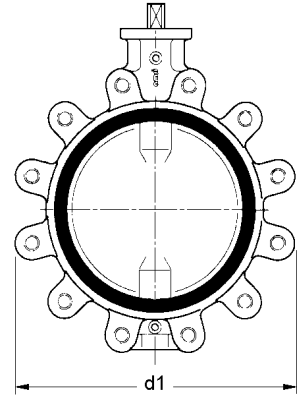

Sizes 350 to 600

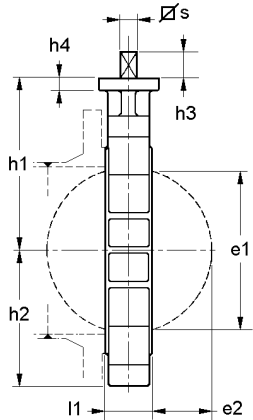

**Size 350⁽²⁾
Size 400 - Size 450⁽¹⁾**

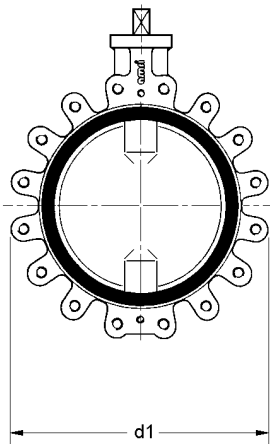

**Size 450⁽²⁾
Size 500 - Size 550
Size 600⁽⁵⁾**

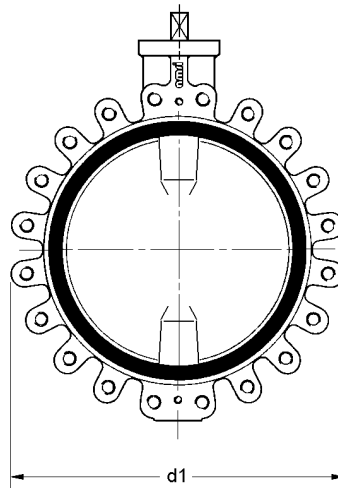

Size 600⁽⁶⁾

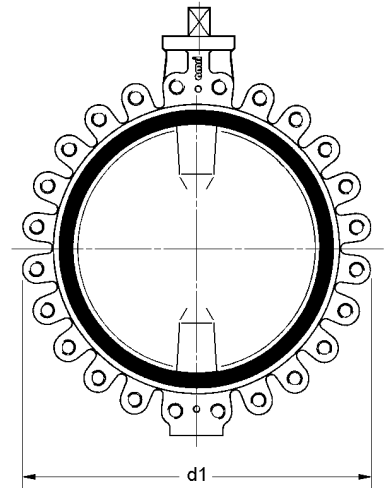

Full-lug type body with raised faces - Type 4

Dimensions (mm) and weight (lbs)

Size		Face to face l1				Mounting plate ISO 5211		Flat shaft end			Square shaft end		Disc clearance		Weight lbs
mm	inch		d1	h1	h2	n°	h4	s	øz	h3	s	h3	e1	e2	
40	1 ½	33	108	105	54	F05	10	11	14	24			32	4	4.4
50	2	43	120	109,5	60	F05	10	11	14	24			33	4	5.5
65	2 ½	46	134	136	67	F05	10	11	14	24			55	11	6.6
80(1)	3	46	140	142	70	F05	10	11	14	24			71	17	8.8
80(2)	3	46	178	142	89	F05	10	11	14	24			71	17	9.9
100	4	52	210	163	105	F05	10	14	18	30			90	23	12
125	5	56	236	176,5	118	F05	10	14	18	30			119	35	19
150	6	56	260	194	130	F07	12	14	18	30			144	46	24
200(3)	8	60	312	222	156	F07	12	19	25	35			196	69	52
200(4)	8	60	322	222	161	F07	12	19	25	35			196	69	55
250	10	68	396	255	198	F10	15	19	25	35			249	92	85
300	12	78	466	282	233	F12	18	22	28	40			297	111	101
350(1)	14	78	510	335	255	F12	23				25	45	326	127	136
350(2)	14	78	530	335	265	F12	23				25	45	326	127	154
400	16	102	598	380	296	F14	23				36	55	370	140	222
450(1)	18	114	622	410	329	F14	23				36	55	422	160	268
450(2)	18	114	654	410	329	F14	23				36	55	422	160	306
500	20	127	708	440	359	F14	27				36	55	470	178	394
550	22	154	774	475	406	F16	27				50	65	522	195	513
600(5)	24	154	822	495	439	F16	27				50	65	566	215	564
600(6)	24	154	830	495	439	F16	27				50	65	566	215	623

- (1) Connection between flanges PN 6, ANSI B16-5 cl. 150, JIS B 2210-5K, BS 10 tables D & E, AS 2129 tables D & E.
(2) Connection between flanges PN 10 & 16 and JIS B 2210-10K & 16K
(3) Connection between flanges PN 6 & 10, ANSI B16-5 cl. 150, AWWA C 207 B, D & E, BS10 tables D & E, AS 2129 tables D & E and JIS B 2210-5K
(4) Connection between flanges PN 16 and JIS B 2210-10K
(5) Connection between flanges PN 10 & 16, ANSI B16-5 cl. 150 and JIS B 2210-5K
(6) Connection between flanges JIS B 2210-10K

Flanged body with flat faces - Type 5 – sizes 150 mm to 1500 mm (6" – 60")

Dimensions (mm) and weight (lbs)

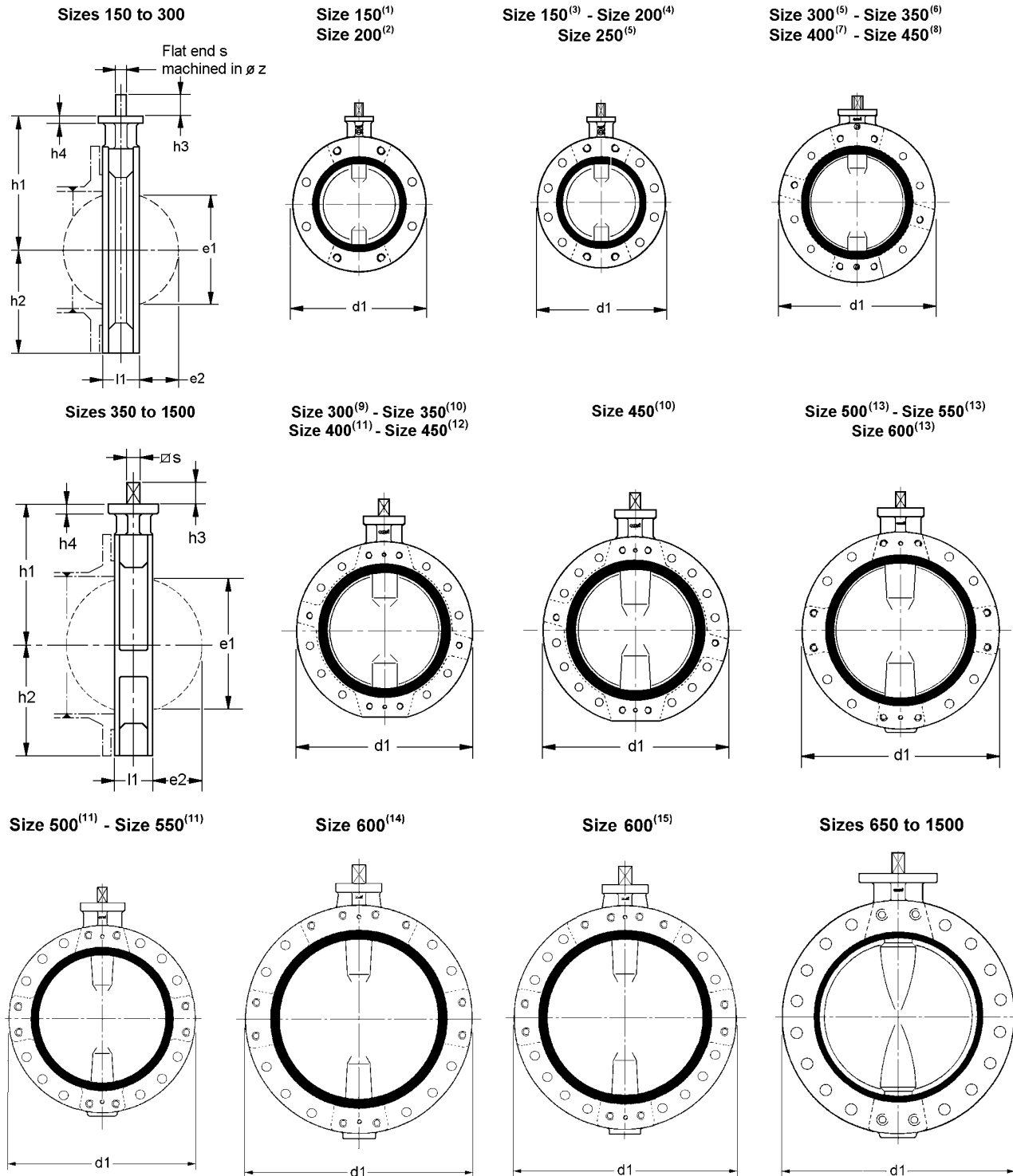

(1) All connections except JIS B 2210-16K

(2) Connections PN 10, ANSI B 16-1 cl 125 & B 16-5 cl 150, AWWA C207 B, D & E, BS 10 tables D & E, AS 2129 tables D & E

(3) Connection JIS B 2210-16 K

(4) Connections PN 16, JIS B 2210-5K, 10K & 16K

(5) All connections except JIS B 2210-10K & 16K

(6) Connections ANSI B16-1 cl 125 & B 16-5 cl 150, MSS SP 44 cl 150, JIS B 2210-5K, AWWA C 207 B, D & E, BS 10 tables D & E, AS 2129 tables D & E

- (7) Connections BS 10 tables D & E, AS 2129 tables D & E
- (8) Connections BS 10 table D and AS 2129 table D
- (9) Connections JIS B 2210-10K & 16K
- (10) Connections PN 10 & 16, JIS B 2210-10K & 16K
- (11) All connections except BS 10 tables D & E, AS 2129 tables D & E
- (12) Connections ANSI B 16-1 cl 125 & B 16-5 cl 150, AWWA C207 B, D & E, MSS SP 44 cl 150, JIS B 2210-5K, BS 10 table E, AS 2129 table E
- (13) Connections BS 10 tables D & E and AS 2129 tables D & E
- (14) All connections except JIS B 2210-5K, 10K & 16K, BS 10 tables D & E, AS 2129 tables D & E
- (15) Connections JIS B 2210-5K, 10K & 16K

Flanged body with flat faces - Type 5

Dimensions (mm) and weight (lbs)

Size		Face to face				Mounting plate ISO 5211		Flat shaft end			Square shaft end		Disc clearance		Weight
mm	inch	l1	d1	h1	h2	n°	h4	s	øz	h3	S	h3	e1	e2	lbs
150	6	56	298	194	149	F07	12	14	18	30			144	46	24
200	8	60	343	222	172	F07	12	19	25	35			196	69	50
250	10	68	406	255	203	F10	15	19	25	35			249	92	88
300	12	78	483	282	242	F12	18	22	28	40			297	111	132
350	14	78	533	335	266	F12	23				25	45	326	127	176
400	16	102	597	380	299	F14	23				36	55	370	140	231
450	18	114	640	410	332	F14	23				36	55	422	160	286
500	20	127	715	440	370	F14	27				36	55	470	178	396
550	22	154	749	475	406	F16	27				50	65	522	195	506
600	24	154	840	495	439	F16	27				50	65	566	215	573
650	26	165	870	535	465	F16	26				50	65	615	235	749
700	28	165	925	560	490	F16	26				50	65	666	260	859
750	30	190	985	590	540	F25	30				60	80	712	272	1046
800	32	190	1055	615	565	F25	30				60	80	763	297	1289
900	36	203	1165	665	615	F25	30				60	80	863	341	1520
1000	40	216	1280	735	680	F25	30				60	90	963	385	1906
1050	42	216	1345	773	717	F25	30				60	90	1045	422	2116
1100	44	216	1345	773	717	F25	30				60	90	1045	422	2116
1200	48	254	1498	840	784	F25	30				60	90	1170	468	2799
1350	54	280	1683	950	890	F30	35				70	110	1353	548	4001
1400	56	280	1683	950	890	F30	35				70	110	1353	548	4001
1500 (1)	60	280	1780	1000	940	F30	35				70	110	1455	597	4453
1500 (2)	60	280	1850	1030	970	F30	35				70	110	1515	627	4684

- (1) Connection between flanges PN 6, 10 & 16, JIS B2210-5K & 10K, BS 10 table D.
- (2) Connection between flanges MSS SP 44 cl. 150, ANSI B 16-1 cl. 125 and AWWA C 207 cl. B, D & E.

U-section body with raised faces - Type 6 – sizes 650 mm to 1500 mm (26” to 60”)

Dimensions (mm) and weight (lbs)

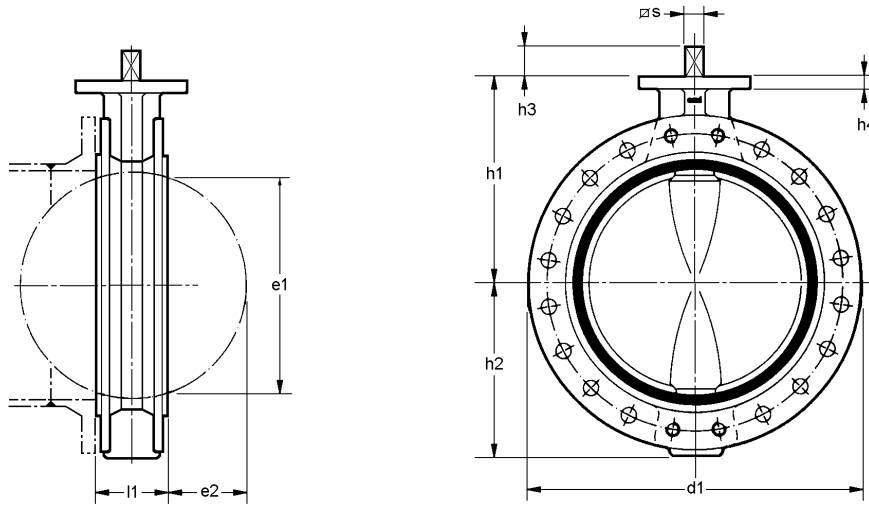

Size		Face to face l1	Mounting plate ISO 5211			Square shaft end		Disc clearance		Weight lbs		
mm	inch		d1	h1	h2	n°	h4	□s	h3		e1	e2
650 (1)	26	165	870	535	465	F16	26	50	65	615	235	639
650 (2)	26	165	895	535	465	F16	26	50	65	615	235	661
700 (3)	28	165	910	560	490	F16	26	50	65	666	260	749
700 (4)	28	165	925	560	490	F16	26	50	65	666	260	749
700 (5)	28	165	960	560	490	F16	26	50	65	666	260	793
750 (6)	30	190	985	590	540	F25	30	60	80	712	272	925
750 (7)	30	190	1020	590	540	F25	30	60	80	712	272	969
800 (8)	32	190	1025	615	565	F25	30	60	80	763	297	1068
800 (9)	32	190	1055	615	565	F25	30	60	80	763	297	1068
900 (10)	36	203	1125	665	615	F25	30	60	80	863	341	1322
900 (11)	36	203	1165	665	615	F25	30	60	80	863	341	1322
1000 (10)	40	216	1255	735	680	F25	30	60	90	963	385	1708
1000 (12)	40	216	1280	735	680	F25	30	60	90	963	385	1708
1000 (7)	40	216	1320	735	680	F25	30	60	90	963	385	1785
1050	42	216	1345	773	717	F25	30	60	90	1045	422	1873
1100 (13)	44	216	1345	773	717	F25	30	60	90	1045	422	1873
1100 (14)	44	216	1405	790	733	F25	30	60	90	1069	438	2149
1200	48	254	1498	840	784	F25	30	60	90	1170	468	2425
1350	54	280	1683	950	890	F30	35	70	110	1353	548	3527
1400	56	280	1683	950	896	F30	35	70	110	1353	548	3527
1500 (15)	60	280	1780	1000	946	F30	35	70	110	1455	597	4001
1500 (16)	60	280	1850	1030	976	F30	35	70	110	1515	627	4144

Dimensions and weight of valves with:

- (1) Cast iron body, except connection between JIS B2210-16K flanges
- (2) Ductile iron body and steel body, all connections
- (3) Ductile iron body, cast iron body and steel body, connection between PN 6, 10 and 16, JIS B2210-5K and 10K flanges
- (4) Ductile iron body, cast iron body and steel body, connection between AWWA C207 cl. B, D and E, BS 10 tables D and E, AS 2129 tables D and E, MSS SP 44 cl. 150
- (5) Ductile iron body and steel body, connection between JIS B2210-16K flanges
- (6) Ductile iron body, cast iron body and steel body, except connection between JIS B2210-16K flanges
- (7) Ductile iron body and steel body, connection between JIS B2210-16K flanges
- (8) Ductile iron body, cast iron body and steel body, connection between PN 6, 10 and 16, JIS B2210-5K flanges
- (9) Ductile iron body, cast iron body and steel body, connection between JIS B2210-10K, AWWA C207 cl. B, D and E, AS 2129 tables D and E, MSS SP 44 cl. 150 flanges
- (10) Ductile iron body, cast iron body and steel body, connection between PN 10 and 16, JIS B2210-10K flanges
- (11) Ductile iron body, cast iron body and steel body, connection between PN 6, AWWA C207 cl. B, D and E, ANSI B16-1 cl.125, BS 10 tables D and E, AS 2129 tables D and E, MSS SP 44 cl. 150
- (12) Ductile iron body and steel body, connection between PN 6 and MSS SP 44 cl. 150 flanges
- cast iron body, connection between PN 6, MSS SP 44 cl. 150, AWWA C207 cl. B, D and E, BS 10 tables D and E, AS 2129 tables D and E flanges

- (13) Ductile iron body and steel body, except connection between MSS SP 44 cl. 150 and AWWA C207 cl. B, D and E flanges
- (14) Ductile iron body and steel body, connection between MSS SP 44 cl. 150 and AWWA C207 cl. B, D and E flanges
- (15) Ductile iron body and steel body, connection between PN 6, 10 and 16, JIS B2210-5K and 10K, BS 10 table D flanges
- (16) Ductile iron body and steel body, connection between MSS SP 44 cl. 150, ANSI B 16-1 cl.125 and AWWA C207 cl. B, D and E flanges

Flanging dimensions

ISORIA 10 valves are designed to be installed between any type of flanges and connection standard currently used. For optional type flanges (for example: slip-on, lap joint...) and raised face flanges, it is necessary to verify the general compatibility of the connection by checking the dimensions shown in the table below.

The following drawings show valve type 1 mounted between flanges. The flanging dimensions' mentioned in this table, are the same for all body types.

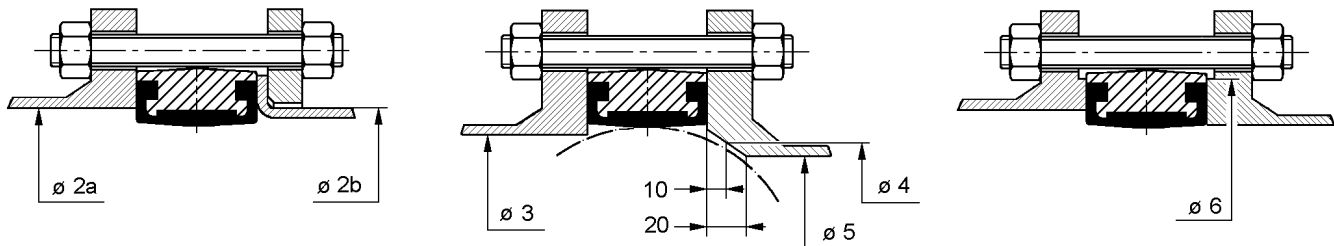

- Fitting between flat flanges: ø2a internal max. tolerated dia. on the supporting area of the flange face.
- Fitting between lap joint flange: ø2b external dia. of the pipe.

Size		Max. dia tolerated (mm)		Min. dia. tolerated on face of flange (mm)	Min. dia. 10 mm from face of flange (mm)	Min. dia. 20 mm from face of flange (mm)	Min. dia. tolerated of shoulder of raised face flange (mm)
mm	inch	ø2a	Ø2b	ø3	ø4	ø5	ø6
40	1 ½	54	49	32	---	---	77
50	2	63	61	33	---	---	86
65	2 ½	80	77	55	13	---	107
80	3	93	89	71	50	---	121
100	4	116	115	90	74	40	141
125	5	141,5	140	119	107	87	171
150	6	170,5 *	169	144	134	120	196
200	8	222 *	220	196	189	178	250
250	10	276,5 *	273	249	243	234	306
300	12	327,5 *	324	297	291	283	358
350	14	361	356	326	321	314	399
400	16	412	407	370	366	358	452
450	18	463	457	422	416	409	505
500	20	515	508	470	464	457	558
550	22	568	561	522	516	509	625
600	24	617	610	566	560	554	664
650	26	667		615	609	602	723
700	28	718		666	661	655	773
750	30	768		712	706	700	830
800	32	819		763	758	752	880
900	36	922		863	858	853	986
1000	40	1027		963	958	953	1093
1050	42	1100		1045	1040	1035	1171
1100(1)	44	1100		1045	1040	1035	1171
1100(2)	44	1134		1080	1075	1070	1205
1200	48	1236		1170	1165	1160	1309
1350	54	1424		1353	1347	1343	1500
1400	56	1424		1353	1347	1343	1500
1500(3)	60	1524		1455	1450	1445	1602
1500(4)	60	1584		1515	1511	1507	1663

* Please check the body is properly centered between the tie – rods.

- (1) Valves fitted between PN 6, 10 and 16, JIS B2210-5K and 10K flanges.
- (2) Valves fitted between MSS SP 44 cl. 150 and AWWA C207 cl. B, D and E flanges.
- (3) Valves fitted between PN 6, 10 and 16, JIS B2210-5K and 10K, BS 10 table D flanges.
- (4) Valves fitted between MSS SP 44 cl. 150, ANSI B 16-1 cl. 125 and AWWA C207 cl. B, D and E flanges.

Installation

ISORIA 10 valves are bi-directional and can be used for on/off or throttling applications. They can be installed in any position, however, for sizes 650 to 1,500 mm, (26" to 60" inch), the valve must not be installed upside-down.

Dead-end service

The design of the body of ISORIA 10 valves allows for dead-end service under maximum allowable pressure.

This mounting requires the use of a counter-flange fitted on the downstream side of the valve. Upstream/downstream leak-tightness is maintained and the valve can be cycled.

Shown type 1 or 2

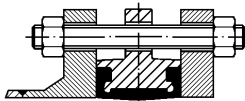

Particular case of type 4

Maximum tightening torque to be applied on the connection bolting:

Size (inch)	Torque (in. lbs.)
1 ½ to 5	443
6 to 14	885
16 to 20	1416
22 and 24	2213

Downstream pipe dismantling

Downstream pipe dismantling under maximum allowable pressure is allowed for ISORIA 10 valves types 2, 4 and 5 and valves type 6 with ductile iron or steel body. This type of mounting allows repair and maintenance on downstream pipe or equipment. During this time, the valve must not be operated.

Type 2

Sizes 40 to 300
1 ½" to 12"

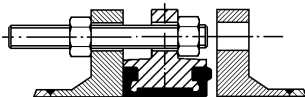

Sizes 350 to 600
14" to 24"

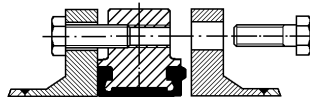

Maximum tightening torque to be applied on the bolting for downstream dismantling, sizes 40 to 300 mm (1 ½" to 12"):

Size (inch)	Torque (in. lbs.)	Size (inch)	Torque (in. lbs.)
1 ½	88	5	283
2	115	6	416
2 ½	142	8	531
3	239	10	717
4	266	12	1186

No maximum torque values for larger sizes. Tighten bolts until flange/body contact is made.

Type 4

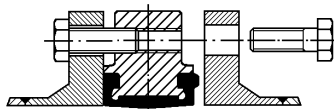

Cast iron body - Maximum tightening torque to be applied on the connection bolting:

Size (inch)	Torque (in. lbs.)
1 ½ to 5	443
6 to 14	885
16 to 20	1416
22 and 24	2213

Ductile iron body – No maximum torque values. Tighten bolts until flange/body contact is made.

Type 5

Sizes 150 to 600 mm
6" to 24"

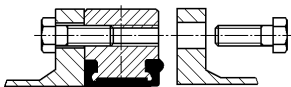

Sizes 650 to 1500 mm
26" to 60"
Mounting with special HS nuts

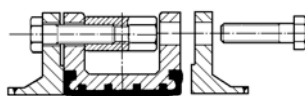

Type 6

Sizes 650 to 1500 mm
26" to 60"
Mounting with special HS nuts

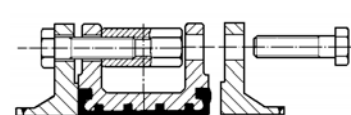

Data to be supplied upon request or when ordering

Media: chemical composition, concentration, % of solids (if any)

Working conditions: pressure, temperature (min., max.), flow rate

Valves sizes and flange standard

Body, disc and liner materials: (if known)

Type of actuator: (manual, double acting pneumatic, spring return pneumatic, electric)

On/off throttling service

Additional accessories required

8444.1/3-10 / 15.01.2000 – This leaflet is not contractual and may be amended without notice.